

Pro.2

4K HDMI Audio Extractor

Model: HA01

Operating Instructions

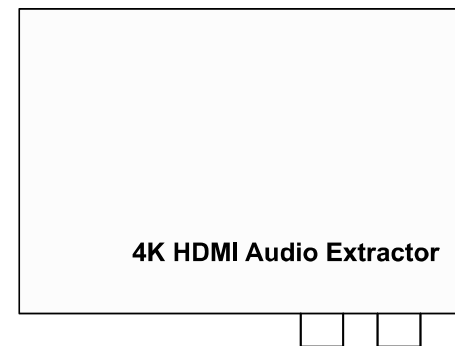

Dear Customer

Thank you for purchasing this product. For optimum performance and safety, please read these instructions carefully before connecting, operating or adjusting this product. Please keep this manual for future reference.

FEATURES

- Extract the digital HDMI audio signal from the HDMI input to 2 channel analog stereo output or 5.1 channel Audio output
- Supports resolution up to 4K@30Hz
- Supports deep color up to 36bit
- Support 3D
- Three Audio Settings: 2.0CH/5.1CH/By pass
- Supports Apple TV and various Blu-ray player, satellite receivers

NOTICE

Our company reserves the right to make changes in the hardware, packaging and any accompanying documentation without prior written notice.

TABLE OF CONTENTS

Specifications

Package Contents

Panel Descriptions

Connecting and Operating

Application Diagram

Maintenance

Product service

Warranty

SPECIFICATIONS

Operating Temperature Range	-5 to +35°C(+23 to +95°F)
Operating Humidity Range	5 to 90%RH (No Condensation)
Input Video Signal	0.5-1.0 Volts P-P
Input DDC Signal	5 volts p-p(TTL)
Support Video format	4Kx2K/1080P/1080i/720P/576P/576i/480P/480i 3D video
Support Video Color Format	xv-YCC/deep color 36bit
Support Audio Format	DTS-HD Master Audio、Dolby true-HD etc.
Data transfer speed rate	10.2Gbps(Maximum)
Power consumption	3watts(Maximum)
Dimension (LxWxH)	89.2x66.7x25mm
Net Weight	175g

Note: Specifications are subject to change without notice. Mass and dimensions are approximate.

PACKING CONTENTS

- 1) Main Unit. Mini 4K HDMI Audio Extractor
- 2) DC 5V Power Supply
- 3) Operating Instructions

PANEL DESCRIPTIONS

Front Panel

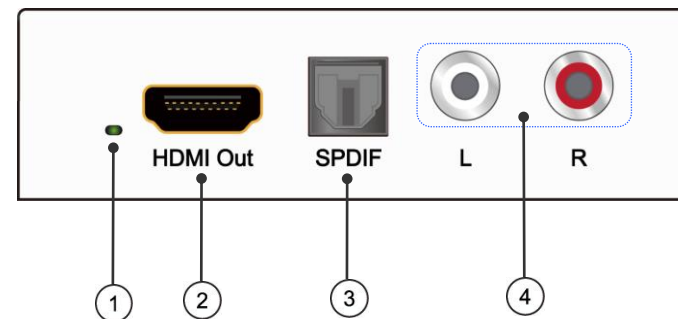

- 1) HDMI out indicator
- 2) HDMI output
- 3) SPDIF Audio output
- 4) Analog Audio output

Back Panel

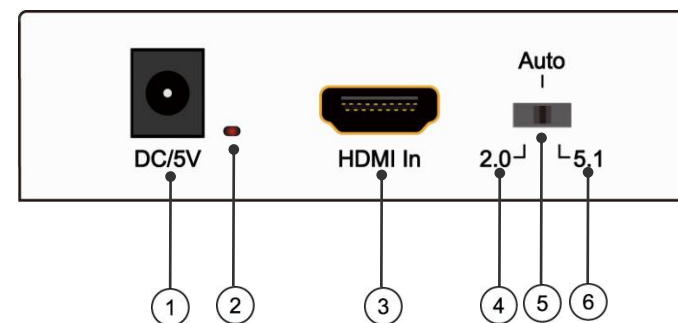

- 1) DC 5V
- 2) Power indicator
- 3) HDMI input
- 4) Switch to 2.0CH Audio
- 5) Switch to Auto mode (by pass)
- 6) Switch to 5.1CH Audio

Connecting and Operating

- 1) Connect the HDMI signal source (Such as PS3, STB etc) into HDMI input of 4K HDMI Audio Extractor.
- 2) Connect the HDMI display device (such as: HD-LCD, HD-DLP) into HDMI output of 4K HDMI Audio Extractor.
- 3) Connect Optical audio cable or RCA audio cable to Amplifier.
- 4) Connect DC 5V power to the 4K HDMI Audio Extractor.

Attention: Insert/Extract cable gently

Application Diagram



- 1 THIS PRODUCT IS WARRANTED FOR 12 MONTHS FROM THE DATE OF PURCHASE.**
Subject to the conditions of this warranty, the Customer Care Centre will perform necessary service on the product without charge for parts, or labour if, in the opinion of the manufacturer/ manufacturer's agent, the product is found to be faulty within the warranty period.
- 2** This warranty only applies if the product has been installed and used in accordance with the manufacturer's recommendations (as noted in the operating instructions) under normal use and reasonable care. The warranty covers normal domestic use only and does not cover damage, malfunction or failure resulting from use of incorrect voltage, accident, misuse, neglect, build-up of dirt or dust, abuse, mis-adjustment of customer controls, mains supply problems, thunderstorm activity, infestation by insects or vermin, tampering or repair by unauthorised persons (including unauthorised alterations), exposure to abnormally corrosive conditions or any foreign object or matter having entered the product.
- 3** If warranty service is required you should:
 - Telephone the Customer Care Centre on 1300 662 946
 - Provide a copy of your purchase receipt that shows retailer's identity and date of purchase.
 - Send or bring the product to your Customer Care Centre.
Please note that freight to and/or from your Customer Care Centre must be arranged by you.
- 4** The warranties hereby conferred do not extend to any costs associated with the delivery, handling, freighting or transportation of the product or any part thereof or replacement of and do not extend to any damage or loss occurring during, or associated with transit.

**THIS WARRANTY CARD AND THE PURCHASE DOCKET
(OR SIMILAR PROOF OF PURCHASE)
SHOULD BE RETAINED BY THE CUSTOMER AT ALL TIMES**

**TROUBLE SHOOTING HELP LINE
1300 662 946**

Customer Care Centre
562 Spencer Street, West Melbourne
VICTORIA 3003

Pro.2
Providing AV Solutions

This advice does not limit, override or later your guaranteed rights under the Australian Consumer Law, including remedies for any failure of the Consumer Guarantees, which may include repair or replacement or it a Major Failure (as defined under the Australian Consumer Law) a replacement or refund. These guaranteed rights cannot be varied by Pro.2 or retailers of its products and have no set time limit.