

# HT5009P

## User Manual



Model No.: BTHT-5009P

# Table of Contents

<b>Box Contents</b> .....	<b>3</b>
<b>Product Introduction (Headphones)</b> .....	<b>4</b>
Product Overview .....	4
Button Functions .....	4
LED Indicators .....	5
<b>Product Introduction (Transmitter)</b> .....	<b>6</b>
Product Overview .....	6
Button Functions .....	7
LED Indicators .....	7
<b>Setting Up</b> .....	<b>8</b>
Connecting to Your TV .....	8
Connecting the Headphones to the Transmitter .....	10
Setting Up Your TV(For Optical Connections Only) .....	11
<b>Charging the Headphones</b> .....	<b>13</b>
<b>Advanced Features</b> .....	<b>14</b>
Listening with a Soundbar .....	14
Adding a Second Pair of Headphones.....	15
Using the Headphones with Your Phone/Tablet .....	16
<b>Specifications</b> .....	<b>17</b>
<b>FAQ</b> .....	<b>18</b>
<b>Contact Us</b> .....	<b>106</b>

# Box Contents



Headphones

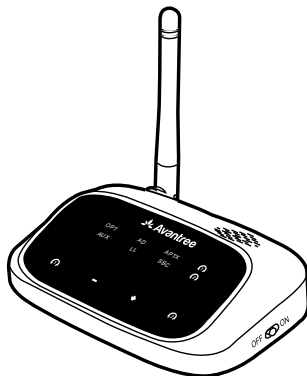

Transmitter

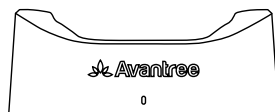

Charging Dock

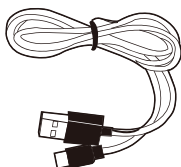

Power Cable for Transmitter

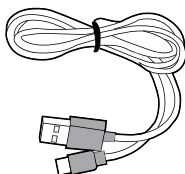

Charging Cable for Headphones

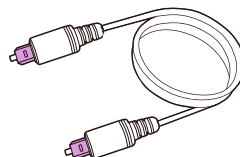

Optical Audio Cable

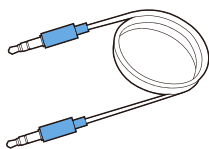



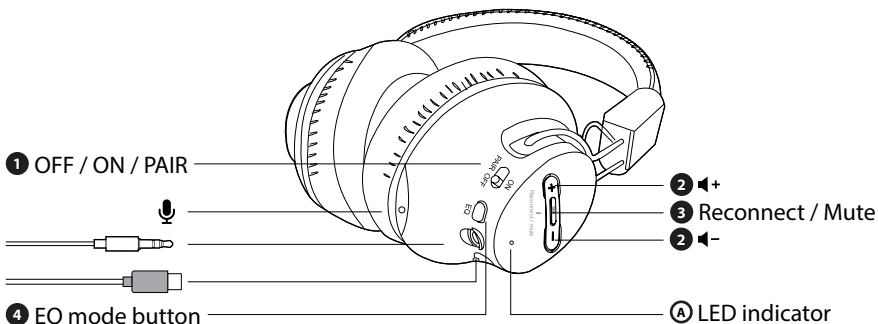

AUX 3.5mm Audio Cable

# Product Introduction (Headphones)

## Product Overview

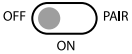

## Button Functions

No.	Button	Functions
<b>1</b>		Switch to "ON / OFF" position to turn the headphones on / off
		Hold in "PAIR" position for 3 seconds to enter pairing mode
<b>2</b>		Press or hold to adjust volume
<b>3</b>		Press once to play / pause audio
		If headphones fail to auto-connect to transmitter, press once to activate reconnection
<b>4</b>		Press once to switch between balanced and clear voice modes

## LED Indicators





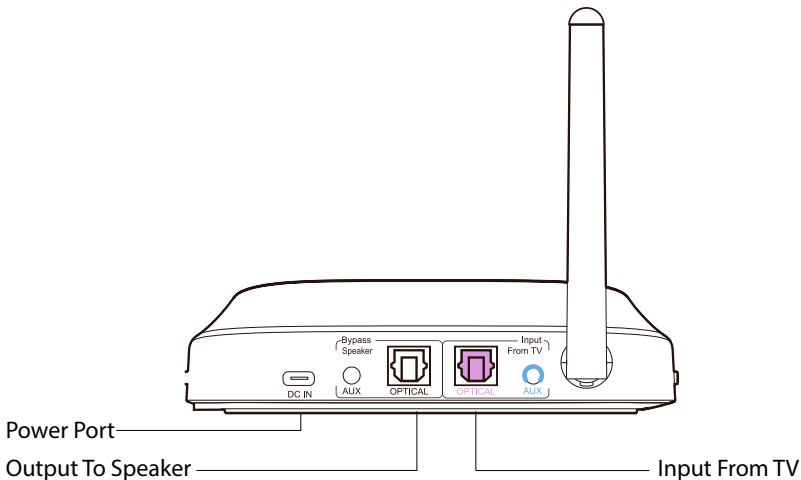
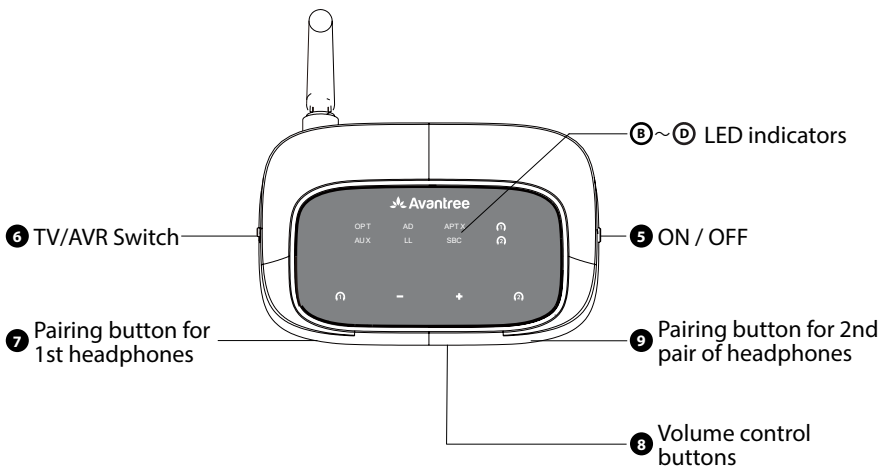

No.	Status	LED Indicator	Voice Prompt
A	Power ON	Solid blue for 1 second	Welcome to Avantree
	Power OFF	Solid red for 2 seconds, then off	Goodbye
	Pairing	Flashing red & blue	Pairing
	Connected	Solid blue	Connected
	Attempting to reconnect	Blue flashes every 2 seconds	N / A
	Low battery	Red flashes	Low Battery
	Charging	Solid red	N / A
	Charging complete	Solid red, then off	N / A

# Product Introduction (Transmitter)

## Product Overview



## Button Functions

No.	Button	Function
5	ON  OFF	Switch to turn the transmitter on / off
6	TV  AVR AUX only	Switch to TV/AVR mode while connecting via AUX cable
7		Press & hold for 2 seconds to enter pairing mode
8	 	Press once to adjust volume
9		Press & hold for 2 seconds to enter pairing mode

## LED Indicators

No.	Indicator	Status
B	Solid white light	Valid audio signal
	Flashing white light	Invalid audio signal
C	Solid white light	Current codec indicator
D	Flashing white & green	Pairing
	Solid white light	Headphones successfully connected

 Avantree

OPT AUX   **B**   AD LL   **C**   APT X SBC   **D**    

# Setting Up

## Connecting to Your TV

The transmitter must be connected to a power source via the provided power cable in order to function. Plug the transmitter into either:

- A TV's USB power port (we recommend this so that they auto power ON / OFF in tandem with your TV), OR
- A nearby wall outlet - 5V / 500mA-2A rated USB charger (e.g. your phone charger should work.) (requires USB adapter, please contact [support@avantree.com](mailto:support@avantree.com) if you'd like to claim a free one)

Once the transmitter is connected to its power source, slide the **ON**  **OFF** switch to the ON position and connect the transmitter to your TV. You can choose one of 3 different ways to do this:

### OPTION 1 Optical port (recommended)

Plug the provided optical audio cable into the TV's optical OUT or OPT OUT port, then plug the other end into the transmitter's optical port in the "INPUT FROM TV" section.

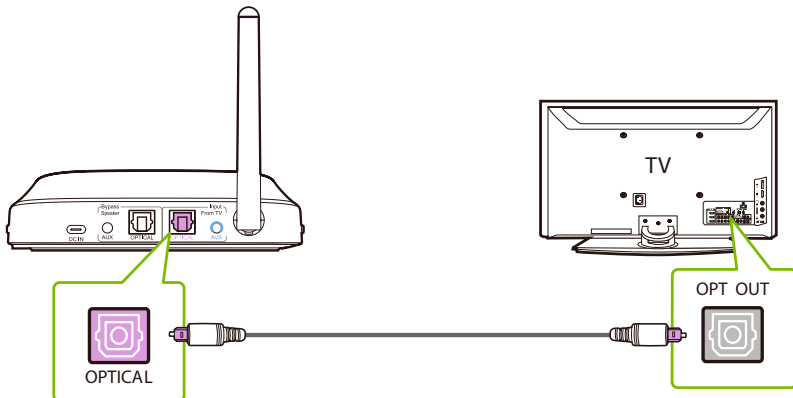



*NOTE: Most TVs support audio output through only one digital output port at a time, so if your TV's HDMI ARC port is in use, the optical port may be disabled. You can either unplug the HDMI ARC, or try connecting the transmitter via RCA / AUX.*

## OPTION 2 AUX 3.5mm port

Plug the provided AUX 3.5mm audio cable into the TV's AUX 3.5mm output port, then plug the other end into the transmitter's AUX 3.5mm port in the "INPUT FROM TV" section.

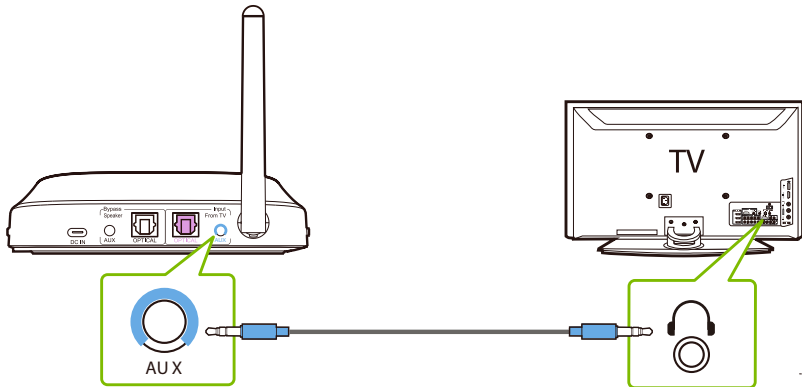

### OPTION 3 RCA port

Connect the provided RCA adapter to the AUX 3.5mm audio cable. Plug the red & white RCA connectors into the TV's "AUDIO OUT" ports, then plug the other end into the transmitter's AUX 3.5mm port in the "INPUT FROM TV" section.

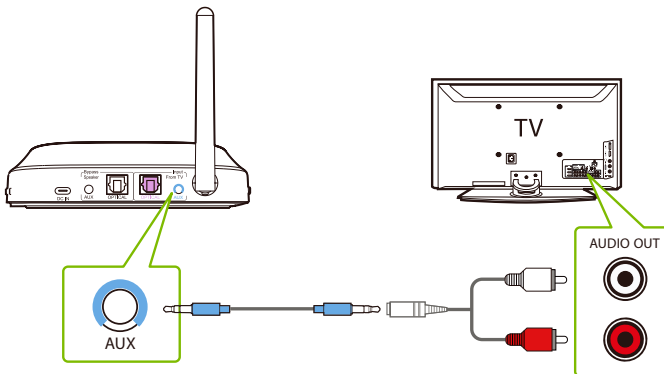

*Note: Double check to ensure that optical / RCA cables are plugged into the TV's audio OUT ports and not the AUDIO IN / COMPONENT IN ports.*

## Connecting the Headphones to the Transmitter

### STEP 1

Power the transmitter on by sliding the  ON  OFF switch to the ON position. The "1" LED will flash white.

### STEP 2

On your headphones, slide the  OFF  ON PAIR switch to the ON position. The LED indicator should start flashing blue.

### STEP 3

Keep the headphones close to the transmitter; they should connect within 3-5 seconds. Once connected, the headphones' LED indicator will turn solid blue, while the "1" indicator on the transmitter will turn solid white.

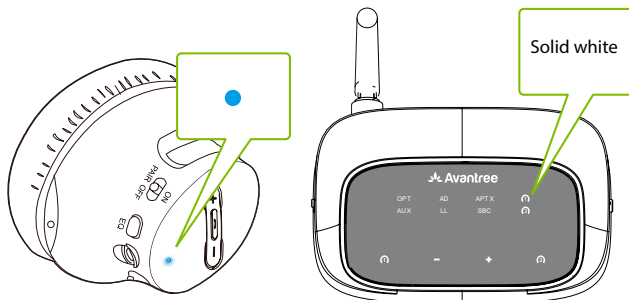

*NOTE: Some smart TVs will automatically scan for and try to pair with any Bluetooth devices in its vicinity. If your TV prompts you to connect your Bluetooth headphones or the transmitter, please "DENY" the request so that your device can properly pair with the transmitter.*

## Setting Up Your TV(For Optical Connections Only)

If you connected to your TV via the optical OUT or "OPT OUT" port, you'll need to configure your TV settings before you'll receive audio.

### STEP 1

Using your TV's remote control, press the SETTINGS button and navigate to the AUDIO tab within the settings menu. (Please note that there may be differences in the setting names depending on your brand of TV).

### STEP 2

Proceed to AUDIO OUTPUT and select "OPTICAL OUT / DIGITAL OUT". Many TVs will do this automatically; skip this step as needed.

**STEP 3**

Set Audio Output format to "PCM / STEREO" ON or "DOLBY" OFF.

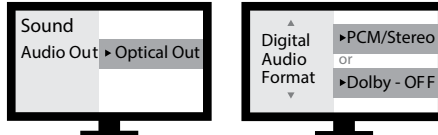

If you're having trouble finding these settings, you can scan the QR code correlating to your TV's brand OR visit [avantree.com/5009p/tv-audio-settings](http://avantree.com/5009p/tv-audio-settings) for a more detailed guide.



LG



Sony



Samsung

*NOTE 1: Smart TVs automatically reset their settings after system updates. Make sure your audio output / input format is set to "PCM" and NOT "AUTO" or "Dolby."*

*NOTE 2: When using Netflix or Amazon Prime, you may need to start the movie / show before changing the audio settings to "PCM."*

# Charging the Headphones

## OPTION 1

Place the headphones on the charging dock to charge, and make sure that the headphones' left side is on the charging dock's left side, otherwise, it won't charge. The charging dock's LED will turn red while charging and off once charging is complete.

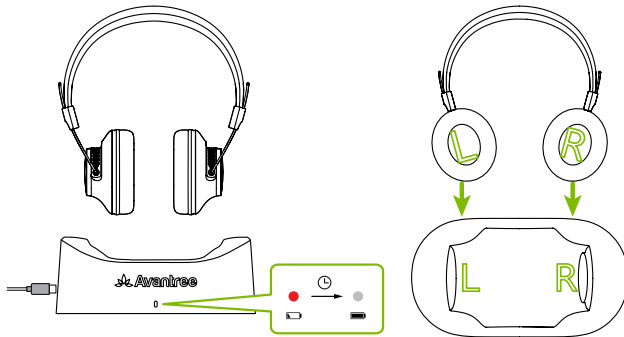

## OPTION 2

You can also charge the headphones with its power port using a charging cable. A solid red light indicates that charging is in progress; once the light turns off, your headphones will be at full battery. It typically takes 2.5 hours to fully charge.

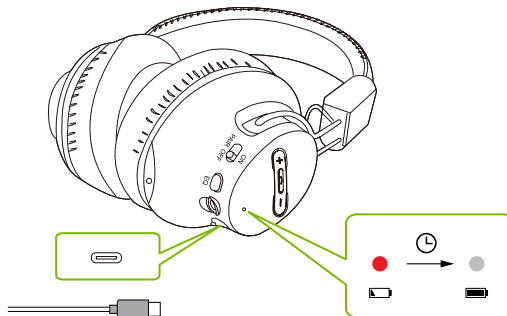

# Advanced Features

## Listening with a Soundbar

The HT5009P's pass-through function allows you to listen through both the headphones and an external soundbar / stereo AVR simultaneously.

### STEP 1

Plug an additional optical, 3.5mm AUX, or RCA audio cable into the correlating audio port in the transmitter's "BYPASS / SPEAKER" section.

### STEP 2

Plug the other end into your external sound system, then you're good to go.

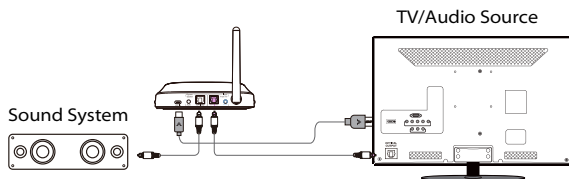

*NOTE: Bypass only works with the same type of input / output, i.e. if you connect to your TV via OPT, you'll need to connect to your speaker via OPT as well.*

## Adding a Second Pair of Headphones

You can add a second pair of HT5009P headphones (Avantree AS19 headphones) to your setup while maintaining low latency.

### STEP 1

Make sure your original HT5009P headphones & transmitter have connected.

### STEP 2

On your transmitter, press & hold the  button until the LED indicator flashes white and green.

### STEP 3

Turn on your second pair of Avantree AS19 headphones, then slide & hold the  switch to the PAIR position until the LED indicator flashes red & blue.

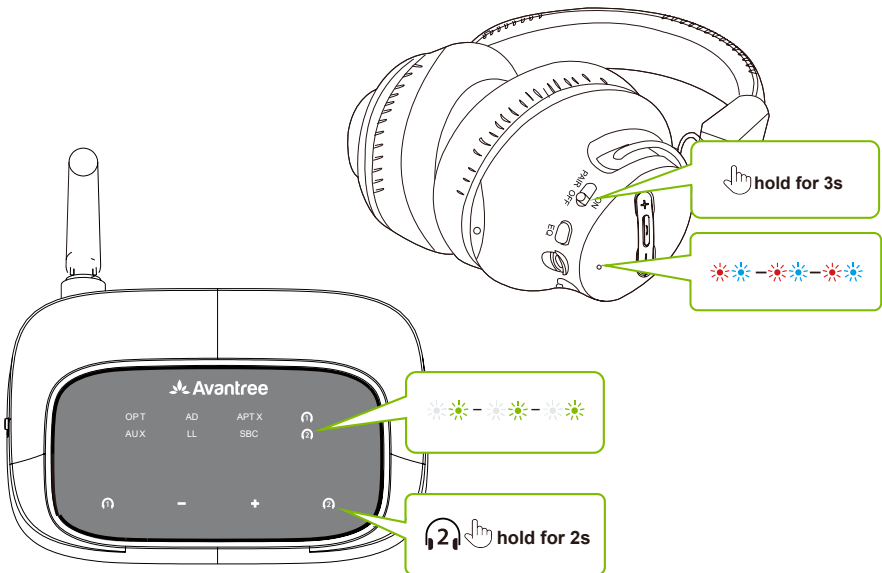

**STEP 4**

Once connected, the headphones' LED indicator will turn solid blue, while the "2" indicator on the transmitter will turn solid white.

To purchase Avantree AS19 headphones, scan the QR code below

**Using the Headphones with Your Phone/Tablet****STEP 1**

Turn off or unplug the transmitter.

**STEP 2**

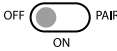
Turn on the headphones, then slide & hold the  switch to the PAIR position until the LED indicator flashes red & blue.

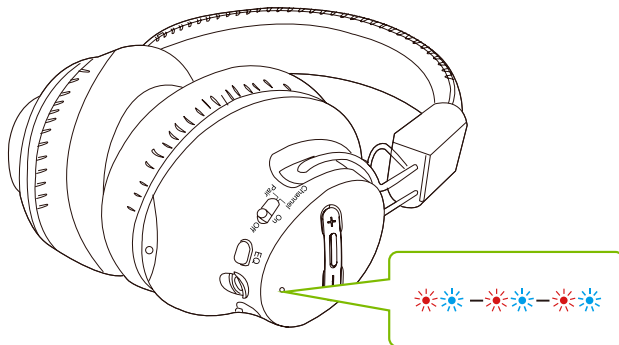
**STEP 3**

Turn on your audio source's Bluetooth and select "Avantree AS19" from the Bluetooth menu.



*NOTE: The headphones are factory locked with the transmitter, so they won't automatically reconnect to your phone / tablet. For subsequent use, you can either slide the  switch to the PAIR position once, or select "Avantree AS19" from your phone / tablet's Bluetooth menu.*

## Specifications

### Transmitter

Bluetooth version	v5.3
Frequency response	20Hz - 20KHz
Operating range	Up to 164ft / 50m
Bluetooth profiles	A2DP, AVRCP
Supported audio codecs	aptX adaptive, aptX-LL, aptX, SBC

### Headphones

Bluetooth version	v5.2
Frequency response	20Hz - 20KHz
Bluetooth profiles	A2DP v1.3.1, AVRCP v1.6, HSP v1.2, HFP v1.7.1
Supported audio codecs	aptX adaptive, aptX HD, aptX, SBC
Battery life	Up to 60 hours
Impedance	32Ω
Net weight	206g

## FAQ

Below are some of the most common questions people have during setup.

### **I have a Samsung / LG TV. Why are my headphones failing to reconnect to the transmitter?**

Samsung / LG smart TVs tend to pair with any Bluetooth devices they can find, which blocks the Avantree headphones from reconnecting to its transmitter. Try following the steps below in order to fix this:

- **DENY the Device** - If a popup appears on your TV asking you to Allow or Deny / Block the device to connect to the TV, you MUST DENY / BLOCK the device from connecting.
- **REMOVE the Device** - If your device is already paired with the TV, you'll need to remove the device in your TV's settings: SETTINGS > GENERAL > EXTERNAL DEVICE MANAGER>DEVICE CONNECTION MANAGER > DEVICE LIST > EDIT > Select all Avantree devices >DELETE. Please note that the routing may differ based on your TV's brand / model.
- **Turn OFF the TV** - Physically turn your TV OFF or pull the plug (the remote control does NOT turn the TV off; it places it into standby mode which still allows the TV to connect to devices).

### **Can I have audio through my TV's speakers and wireless headphones at the same time?**

This completely depends on whether or not your TV supports the ability to output audio to 2 devices simultaneously. You can try a few different methods to test if your TV is capable of this or not -- please refer to [avantree.com/HT5009P/sound](http://avantree.com/HT5009P/sound) for more details.

### **Why aren't I getting sound when watching Netflix / Amazon Prime?**

.....

For answers to questions like these and for a full FAQ list, you can visit [avantree.com/support/HT5009P](http://avantree.com/support/HT5009P), or you can contact us directly for additional assistance.

## Contact Us



**Support Tickets** [avantree.com/submit-a-ticket](https://avantree.com/submit-a-ticket)

---



**Support Email** [support@avantree.com](mailto:support@avantree.com)

---



### Support Numbers

US	+1 800 232 2078	9am-6pm PST	Mon-Fri
CA	+1 800 232 2078	9am-6pm PST	Mon-Fri
UK	+44 208 068 2023	9am-6pm GMT	Mon-Sat
DE	+49 322 2109 7297	11am-9pm CET	Mon-Sat
FR	+33 17 634 0312	11am-9pm CET	Mon-Sat
IT	+39 069 4803 330	9am-6pm CET	Mon-Sat
ES	+34 93 1786 261	9am-6pm CET	Mon-Sat
AU	+61 2 8310 9897	11am-7pm AEST	Mon-Fri

---



**FAQ** [avantree.com/support/ht5009p](https://avantree.com/support/ht5009p)

---



**Video Guide** [avantree.com/ht5009p/video](https://avantree.com/ht5009p/video)

---



**Product Registration** See QR code on the product tag.



**EU Importer and Responsible Person:**

Avantree Europe Z O.O.  
Ul.  Ołnierzy I Dywizji Wojska  
Polskiego 78a/2 84-230 Rumia  
Pomorskie, Poland  
+48 22 307 25 37  
support-eu@avantree.com

**Manufacturer:**

Avantronics Limited  
Luohu District, Shenzhen 518000 China  
+ 86 755 8228 5022  
support@avantronics.com

**Battery Manufacturer and Responsible Person:**

Shenzhen Keruilong Technology Co., Ltd.  
Fudigang Second Industrial Zone, Pingdong  
Community, Pingdi Street, Longgang, Shenzhen, China  
+86 137 1380 2030 3354641970@qq.com

**US Importer:**

Avantree Corporation  
San Jose, California 95119 USA  
+1 800 232 2078  
support@avantree.com

**UK Importer:**

Avantree Limited  
Watford, WD180 0HQ UK  
+44 20 8068 2023  
support-uk@avantree.com



Item No.: BTHT-5009P

Model No.: BTHS-AS9 ; BTTC-500P

FCC ID: 2A1TF-BTHS-AS9S ; 2A1TF-BTTC-500P

IC: 8475A-AS9 ; 8475A-TC500P

Made in China

Z-PKQG-5009P-BLK-V0